

OP-S10G32-40

10Gbps SFP+ Bi-Directional Transceiver, TX1330/RX1270 40km Reach

Features

- Supports 9.95Gb/s to 10.3Gb/s data rates
- Simplex LC Connector Bi-Directional SFP+ Optical Transceiver
- Uncooled 1330nm DFB laser transmitter and PIN photodetector
- Up to 40KM transmission on SMF
- Built-in digital diagnostic functions
- Single 3.3V power supply
- Hot-pluggable SFP footprint
- Low power consumption
- Compliant with SFP+ MSA and IEEE803.ae
- Compliant with RoHS



Applications

- 10GBASE-BX Ethernet
- Other Optical Links

Description

OPTIENT Bidi SFP+ transceiver is designed for single fiber Bidirectional serial optical data communication up to 40KM on SMF. The module transmitter section uses a 1330nm DFB laser and is a Class 1 laser compliant according to International Safety standard IEC 60825. The receiver section consists of a PIN photodiode integrated with a TIA. It is compliant with Multi-Sourcing Agreement (MSA) SFF-8431 and SFF-847.

Absolute Maximum Ratings

Parameter	Symbol	Min.	Max.	Unit
Storage Temperature	Ts	-40	85	°C
Supply Voltage	Vcc	-0.5	4	V
Operating Humidity	RH	5	95	%
Power Consumption			1.5	W

Recommended Operating Conditions

Parameter	Symbol	Min.	Typical	Max.	Unit
Operating Case Temperature	Tc	0		70	°C
Power Supply Voltage	Vcc	3.15	3.3	3.45	V



Optinet Technology Co., Ltd

Add: 4th Floor Xiufeng Industrial Park, Buji Street, Longgang District, Shenzhen, China 518112

Tel: +86-755-28471034 Fax: +86-755-61824579

www.optinetec.com sales@optinetec.com

Power Supply Current	Icc			290	mA
Data Rate	-		10.3125		Gbps

Optical Characteristics

Parameter	Symbol	Min.	Typical	Max.	Unit
Transmitter					
Centre Wavelength	λ_c	1320	1330	1340	nm
Average Output Power	Po	0		4	dBm
Extinction Ratio	Er	3.5			dB
Spectral Width(RMS)	$\Delta\lambda$			1	nm
Optical Modulation Amplitude	OMA	-5.2			dBm
Transmitter and Dispersion Penalty	TDP			3.2	dB
Relative Intensity Noise	RIN			-128	dB/Hz
Pout @TX-Disable Asserted	Poff			-35	dBm
Output Optical Eye Mask	Compliant with IEEE 802.3-2008				
Receiver					
Center Wavelength	λ_c	1260	1270	1280	nm
Receiver Sensitivity	S			-15	dBm
Receiver Overload	P _{in}	0.5			dBm
LOS De-Assert	LOS _D			-17	dBm
LOS Assert	LOS _A	-30			dBm
LOS Hysteresis		0.5			dB

Notes:

1. The optical power is launched into SMF
2. Measured with a PRBS 2³¹-1 test pattern @10.3125Gbps
3. Measured with a PRBS 2³¹-1 test pattern @10.3125Gbps, BER ≤ 1x10⁻¹²
- 4.

Electrical Characteristics

Parameter	Symbol	Min.	Typ.	Max.	Unit
Transmitter					
Differential Data Input Swing	Vin	180		700	mV
Input Differential Impedence	Zin		100		Ω
TX_Fault	Normal Operation	0		0.5	V
	Transmitter Fault	2		Vcc	V
TX_Disable	Laser Enable	0		0.8	V



Optinet Technology Co., Ltd

Add: 4th Floor Xiufeng Industrial Park, Buji Street, Longgang District, Shenzhen, China 518112

Tel: +86-755-28471034 Fax: +86-755-61824579

www.optinetec.com sales@optinetec.com

	Laser Disable		2		Vcc+0.3	V
Receiver						
Differential Data Output Swing		Vout	300		850	mV
Output Differential Impedence		Zo		100		mV
Rx_LOS	Normal Operation		0		0.5	V
	Loss of Signal		2		Vcc	V

Digital Diagnostic Function

OPTINET Bidi SFP+ transceiver supports the 2-wire serial communication protocol as defined in SFP MSA. The standard SFP serial ID provides access to identification information that describes the transceiver's capabilities, manufacturer, part no and other information.

Additionally, the digital diagnostic monitoring interface also defines another 256-byte memory map in EEPROM, which makes use of the 8 bit address 1010001X (A2h). It allows real-time access to transceiver's working temperature, laser bias current, transmitted optical power, receiver sensitivity and supply voltage.

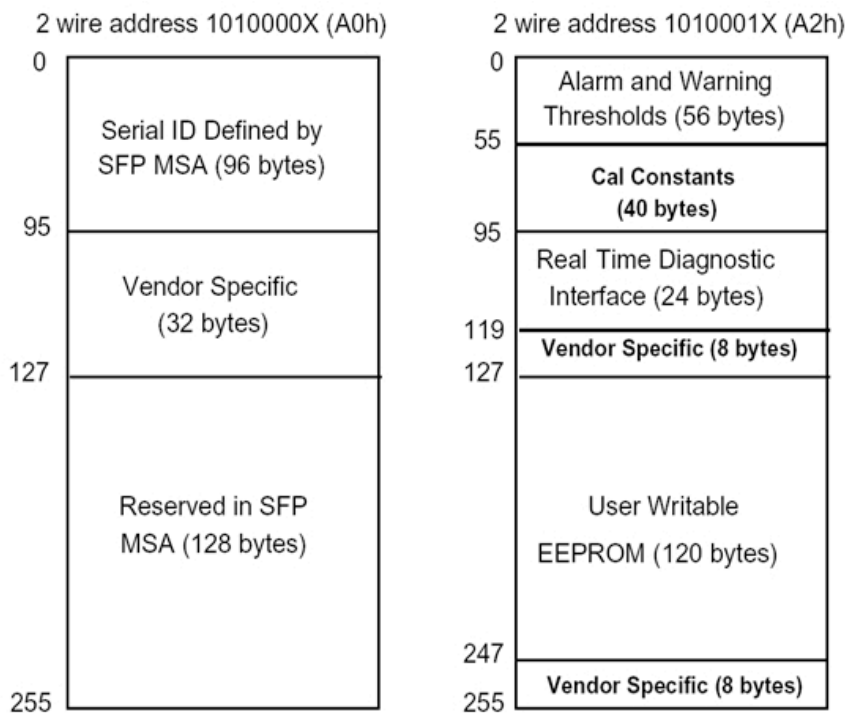

Pin Definitions

Diagram of Connector Block Pins on Host Board

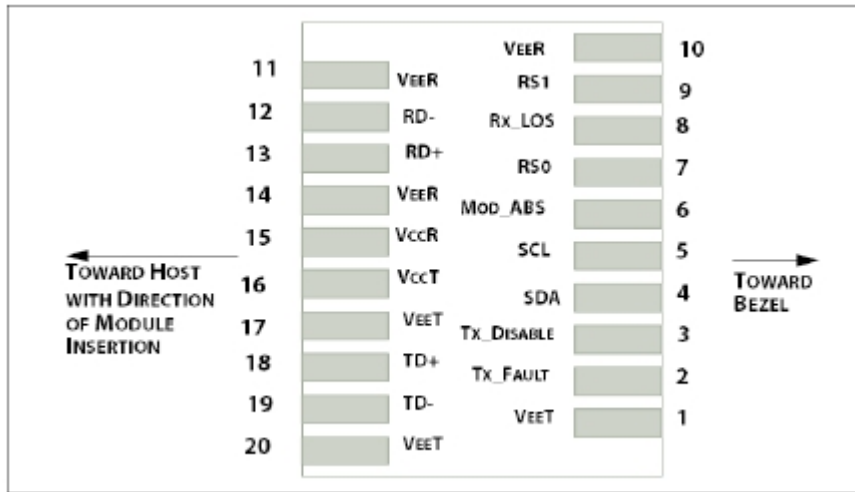

Pin	Symbol	Name/Description
1	VeeT	Transmitter Ground
2	Tx_FAULT	Transmitter Fault
3	Tx_DISABLE	Transmitter Disable. Laser output disabled on high or open
4	SDA	2-wire Serial Interface Data Line
5	SCL	2-wire Serial Interface Clock Line
6	MOD_ABS	Module Absent, connected to VeeT or VeeR in the module
7	RS0	Rate Select 0, not implement
8	RX_LOS	Receiver loss of signal
9	RS1	Rate Select 1, not implement
10	VeeR	Receiver Ground
11	VeeR	Receiver Ground
12	RD-	Receiver Inverted Data Output
13	RD+	Receiver Non-Inverted Data Output
14	VeeR	Receiver Ground
15	VccR	Receiver Power Supply
16	VccT	Transmitter Power Supply
17	VeeT	Transmitter Ground
18	TD+	Transmitter Non-Inverted Data Input
19	TD-	Transmitter Inverted Data Input
20	VeeT	Transmitter Ground

Notes:

1. The Module ground pins are isolated from the module case
2. The pins should be pulled up with 4.7k – 10kΩ to a voltage between 3.15V and 3.6V on host board
3. The pins is pulled to VccT with 4.7 kΩ to 10kΩ resistor in the module
4. The pins are pulled low to VccT with a > 30 kΩ resistors in the module

Recommended Host Board Power Supply Unit

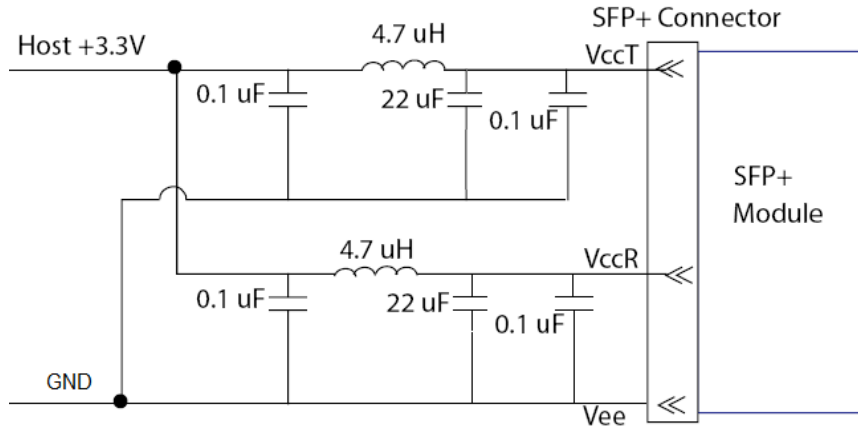

Recommended Interface Circuit

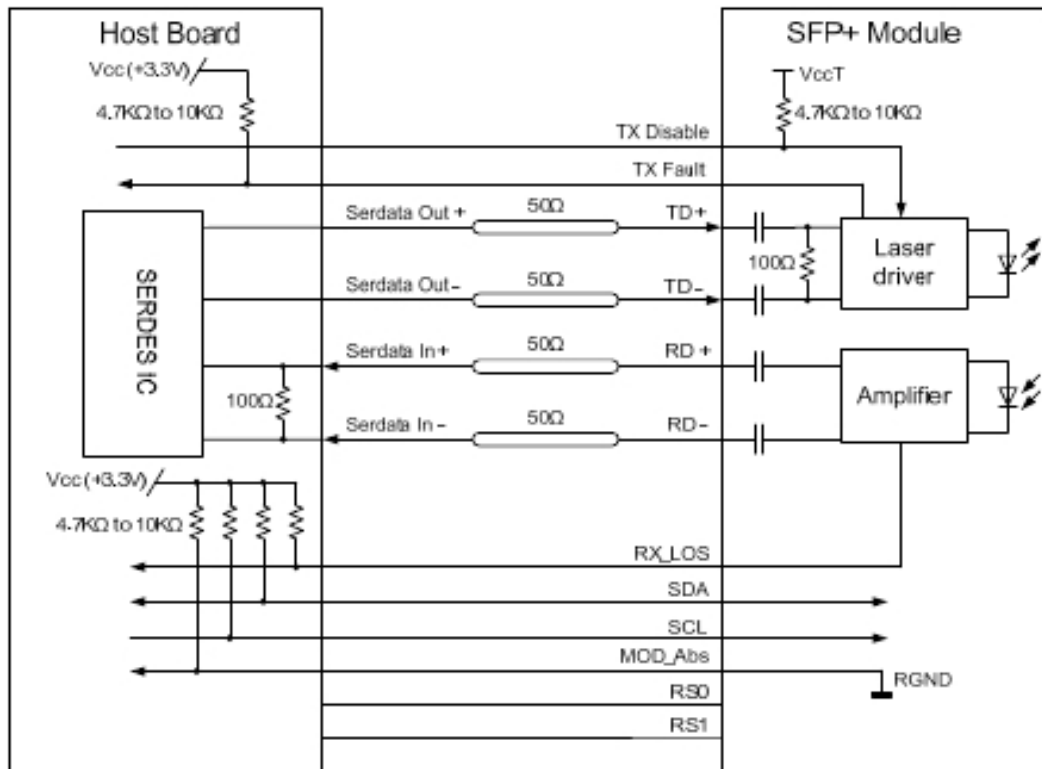

Mechanical Diagram

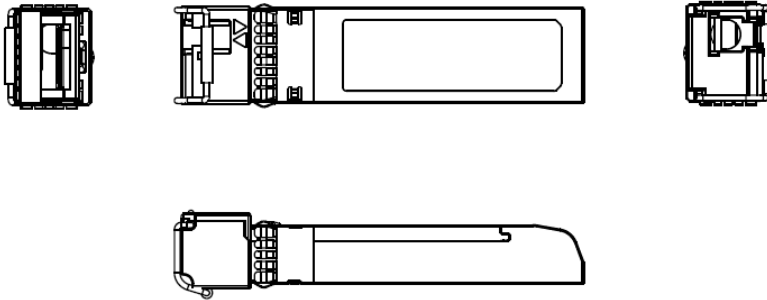
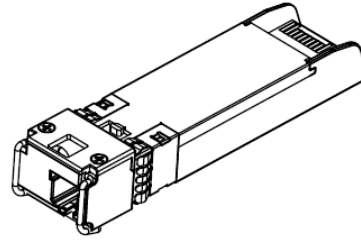
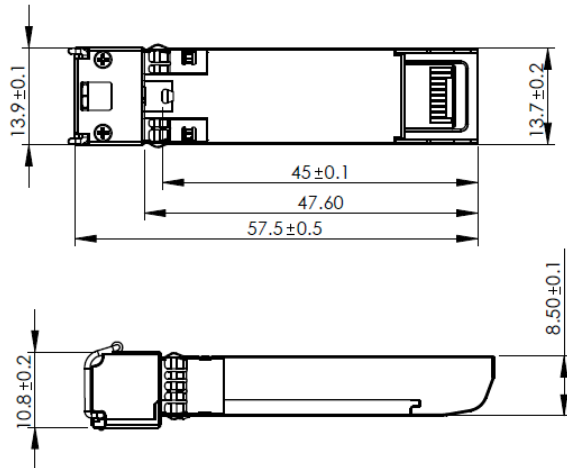

Ordering Information

Part No	Data Rate	Wavelength	Fiber	Reach	Temp	DDM
OP-S10G23-40	10Gbps	Tx1270/Rx1330nm	SMF	40KM	0~70°C	YES
OP-S10G32-40	10Gbps	Tx1330/Rx1270nm	SMF	40KM	0~70°C	YES
OP-S10G23-40E	10Gbps	Tx1270/Rx1330nm	SMF	40KM	-10~80°C	YES
OP-S10G32-40E	10Gbps	Tx1330/Rx1270nm	SMF	40KM	-10~80°C	YES
OP-S10G23-40I	10Gbps	Tx1270/Rx1330nm	SMF	40KM	-45~85°C	YES
OP-S10G32-40I	10Gbps	Tx1330/Rx1270nm	SMF	40KM	-45~85°C	YES

Warnings

Handling Precautions: This device is susceptible to damage as a result of electrostatic discharge(ESD). A static free environment is highly recommended. Follow guidelines according to proper ESD procedures.

Laser Safety: Radiation emitted by laser devices can be dangerous to human eyes. Avoid eye exposure to direct or indirect radiation.